



Cott Vending Inc.

The Leader in Premium Retailer Brand Beverage Innovation

THESE GUIDES ARE FOR MACHINE MODEL: DIXIE-NARCO 440 ONLY

Store Level Vending Responsibilities

Two employees at each store should be designated, and trained to operate your retail brand vending machine, to enable them to perform the following:

- **Cleaning the machines, both inside and out, - weekly**
- **Load the machines correctly with product, - daily**
- **Empty cash box, - daily**
- **Report machine malfunctions to Cott (Call 1-800-662-9225, option 1 for service assistance or to diagnose the problem.)**
- **Perform over the telephone, troubleshooting and diagnostics**
- **Clear coin jams**
- **Clear can jams**
- **Change flavor strips**
- **Minor part replacement**

NOTE: Under the Cott vending program, your employees will be asked to assist in performing over the phone diagnostics, troubleshooting and minor repairs. It is our experience that the vast majority of malfunctions are caused by jammed coins, jammed bottles or cans, store-level electrical problems or cleanliness issues. By partnering with our retailers and their on-site staff, in most cases the malfunctioning machine can be corrected within minutes. In the event that the store staff is unable to correct the problem, Cott will dispatch a contract service company to the store site within two business days.

If parts are necessary, Cott will ship them via UPS to either the store or the contract service company, as appropriate. If parts have been sent to the store for installation by store staff, Cott may request that certain old parts be returned to Cott's Service Center. Cott handles the return of these parts via UPS ARS labels, at no cost to the store.

The Cott Service Center will automatically contact the store later to verify that the problem has been resolved. The regular service response time frame does not apply to machines damaged by theft or vandalism.

Machines damaged by vandalism should be reported to the Cott Service Center at 1-800-662-9225, option 1, as soon as possible. Please provide as complete a record as possible to help determine the parts and graphic components necessary to repair the machine. Cott will dispatch a service technician to your store to estimate the machine damage and repair the machine if possible.

How do I replace the coin changer in my machine?



This is an exchange item!

If the part is not returned to Cott Beverages, your store will be billed for the cost of this changer (up to \$200.00). Please put the old changer into the box the new one came in, place the supplied UPS label on the box, and give the box to your UPS driver. The part will be returned at no cost to you.

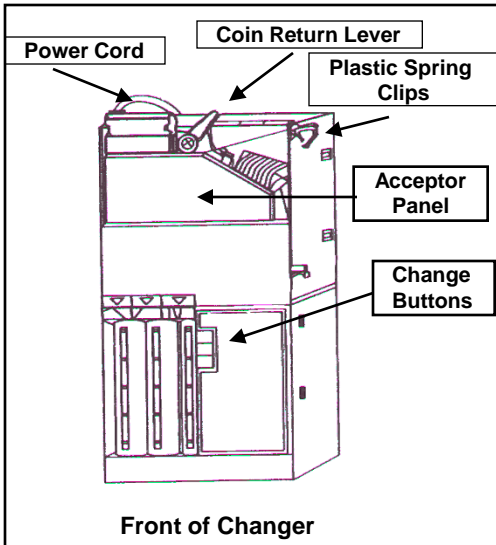
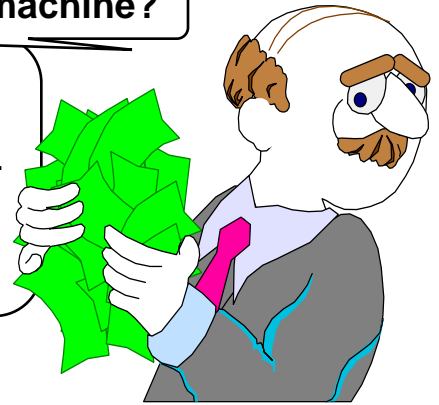

Front of Changer

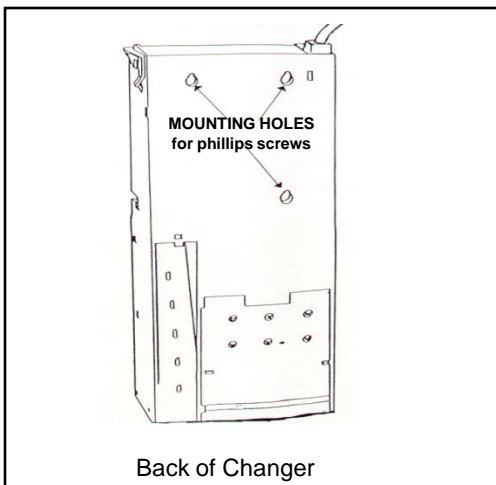

Back of Changer

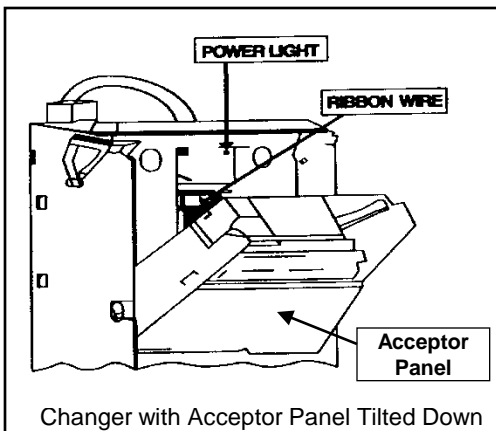

Changer with Acceptor Panel Tilted Down

MOUNTING INSTRUCTIONS.....

- 1) **Disconnect power to your machine by unplugging it from the wall or by switching the circuit breaker off at the store's main power panel.**
- 2) Open the front door of the machine and the inner door. Find the changer power cord, located at the top left, rear corner of the changer.
- 3) Follow the power cord to the large plug on its end.
- 4) Grasp the plug and pull it out of its door-mounted socket.
- 5) Find the two plastic spring loaded clips on either side of the changer. Gently push them upwards with your thumbs and tilt the acceptor panel forward with your fingertips.
- 6) Disconnect the flat "ribbon" wire that leads from the acceptor to the body of the changer by grasping the wire and carefully pull it toward you.
- 7) Remove the acceptor from the changer. Three shiny phillips screw heads should be visible (one in each upper corner of the changer and one on the left side approximately four inches below the one at the top corner). Loosen these screws approximately one turn.
- 8) Lift changer body up approximately 1/4 inch and pull toward you. You should be able to remove it completely from the machine.
- 9) Remove new acceptor panel from new changer and install the new changer body on the three phillips mounting screws. Tighten screws **GENTLY!! DO NOT OVER TIGHTEN !!!**
- 10) **Fill change tubes with nickels, dimes and quarters.**
- 11) Re-install new acceptor in new changer. Carefully, plug ribbon wire into changer body. **BE SURE MAIN COIN CHANGER PLUG IS NOT CONNECTED WHILE DOING THIS!**
- 12) Tilt the top of the acceptor upward until it snaps into place and the plastic spring clips hold it.
- 13) Plug the changer main plug back into the door-mounted socket.
- 14) Plug machine back into the wall or re-set circuit breaker at store's main power panel. Close the machine's doors.
- 15) Return the old changer to Cott Vending, so your store will not be billed for its value.

Questions? Call Cott Vending Inc. at (800)662-9225, option 1.

Coins are falling straight through or getting stuck & I am unable to purchase a soda. What do I do?

Try the steps listed below. If you still have difficulties, call us at (800) 662-9225, option 1.

It is possible that the coin changer is just dirty. Since all coins share a common ramp, it gets heavy usage and dirt build-up.

1. Disconnect power to your machine by unplugging it from the wall or by switching the circuit breaker off at the store's main power panel.
2. Open the front door of the machine and the inner door. Find the coin changer power cord, located at the top left, rear corner of the coin changer.
3. Follow the power cord to the large plug on its end.
4. Grasp the plug and pull it out of its door-mounted socket.
5. Press down on the plastic coin return lever, at the top of the coin changer. This will cause the front half of the coin acceptor to move toward you. Insert your fingertip between the halves of the acceptor panel on the left side.
6. You should now be able to lift up on the left side of the acceptor gate panel, to expose the inner ramp. The acceptor gate panel is spring loaded at the top right corner. Do not lift the left side more than 90 degrees. (ie. Do not lift past the point of significant resistance.) Hold the acceptor gate firmly to prevent it from snapping back.
7. Wipe the exposed inner surfaces on both halves of the acceptor with a damp cloth and mild soapy water solution. **NEVER USE LUBRICANTS, OIL, OR HARSH CLEANERS WHICH COULD DAMAGE THE COIN CHANGER.**
8. **DO NOT SUBMERGE THE COMPONENTS IN WATER !!**
9. Dry the surface and gently release the acceptor gate panel so that it returns to its normal position.
10. Plug the coin changer's main plug back into the door-mounted socket.
11. Close the inner and outer door of the machine. Plug the machine back into the wall, or reset the circuit breaker at the store's main power panel.
12. Coin test the machine for proper operation.

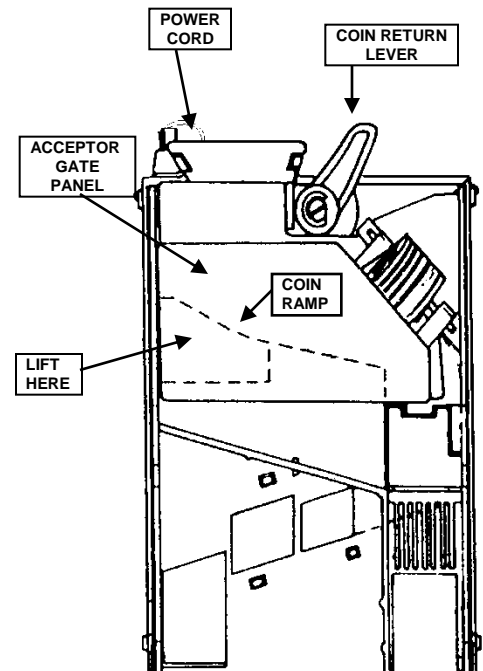

If the coins are still falling straight through, see guide titled “Basic Trouble Shooting Information for Common Problems” or call the Vending Customer Service Center at (800)662-9225, option 1.

Basic Troubleshooting Information For Common Problems.

**I. If coins fall to the coin return, answer the questions below and complete the following steps.
(If the machine is keeping your money go to (II) on next page.)**

1. Is there power to the machine? (Be certain) _____
2. Are the fluorescent (main front door) lights on? _____
3. Is the machine cooling your product? _____

Clean the coin acceptor (See attached instructions). If the problem persists, continue to next step.

Next...

On the front of the changer, press the cash pay out (CPO) buttons. (Red, white and blue)

4. Do they all work? _____
5. Is the flat, grey ribbon wire connected inside the changer? _____
6. Is there at least one inch of coins stacked in each coin column? _____

If no, add change and check the operation. If yes, continue to next step.

7. Does coin return lever or button, return to its normal position? _____

If no, Check to see if the return spring is in place inside and call the service number. If yes, continue to step 8.

******IMPORTANT******

8. Are any of the selections indicating a false 'sold out', where the column is full? _____

If there are false sold out lights, check for jammed product or vend motors at the bottom of the column. Clear the jam(s) and check the operation of the machine. (See attached sheets for clearing jammed columns and testing vend motors.)

There is a vend meter just above the changer (looks like an odometer). Check the far right number.

9. Is it resting on a whole number or is it in between numbers? _____

If it is resting in between numbers, try pushing each product select button on the front selection panel.

10. Did any of the selections vend? _____

If no, unplug the changer for a count of 20 and plug it back in. If the counter remains in between two numbers, unplug the machine and see if it resets to a whole number when plugged back in.

11. Is it vending now? _____

If no, Call Cott Vending Inc., at 1-800-662-9225. Be prepared to give detailed information regarding the answers to each question in this checklist.

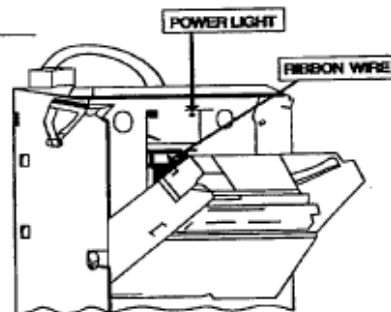
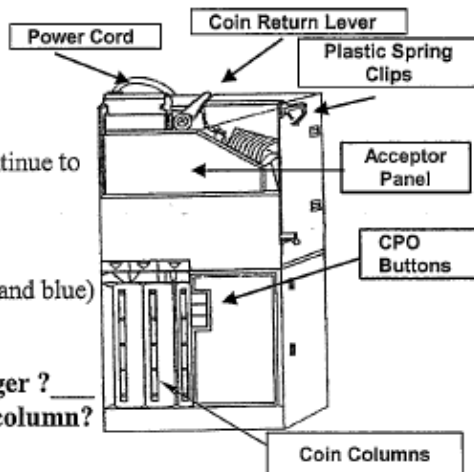

- II. If the machine keeps the money, but does not vend, follow these steps below.
1. Check to see if the money is just jamming in the changer or the coin chute. This could be the problem. Try to clear the jam and attempt a sale. If the coins go to the coin box near the bottom of the door, go to step 2.
 2. Check the cash pay out (CPO) buttons on the changer. Do they eject coins? _____
 3. Locate the counter and look at the number on the far right. Take coins and insert them into the top of the changer. Did the number move to the next number?
 - a. If the counter moved to the next number, check the vend relay. This is a clear, square, plastic cube located near the plug end of the changer power cord. Make sure the relay is plugged in firmly. Try inserting coins into the changer again. Is the counter still moving?
 4. Does the machine refund your money when you depress the coin return on the front of the machine?
 - a. If yes, refer to the instructions for setting the vend price.

If the changer is still not working call Cott Vending at 1-800-662-9225 with answers to the above questions.

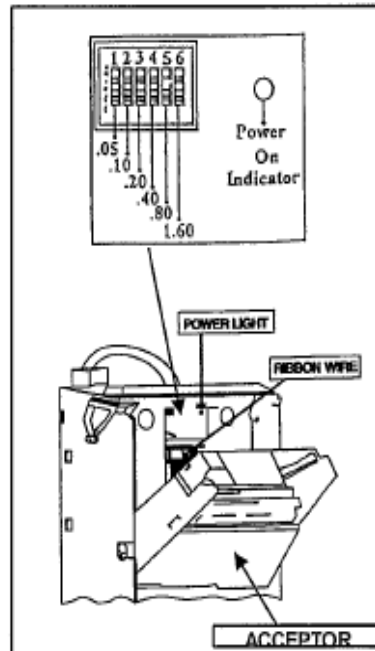
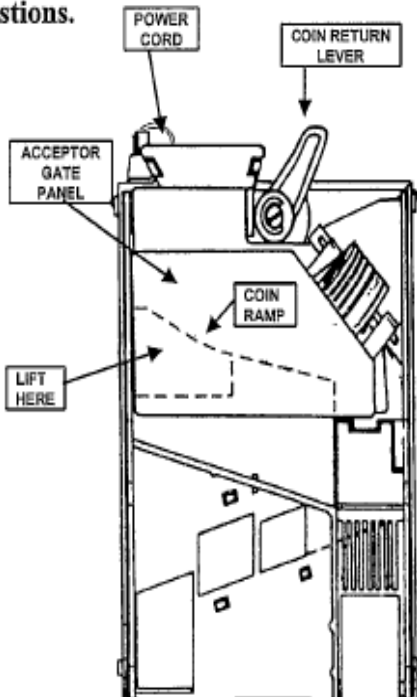

How do I set the correct vend price of my machine?

Try the steps listed below. If you still have difficulties, call us at (800) 662-9225, option 1.



Price Setting Instructions for Single-Price Machines

1. Find the coin mech power cord located at the top left rear corner of the coin mech. Follow the power cord to the large plug on its end.
2. Grasp the plug and pull it out of its door-mounted socket.
3. Find the two plastic spring loaded clips located on either side of the top of the coin mech. Gently push them upward with your thumbs and tilt the acceptor panel forward with your fingertips as far as it will go.
4. Located in the upper portion of the changer is a switch module with 6 very small rocker switches. (See Diagram 1)

When the top of the rocker switch is pushed in, it is in the ON position. The switches correspond as follows:

- 1 = \$.05
- 2 = \$.10
- 3 = \$.20
- 4 = \$.40
- 5 = \$.80
- 6 = \$1.60

The vend price is set by adding the value of switches 1-6, which are in the ON position. *Example: switches 1,3 & 4 in the ON position equals a 65 cent vend price.*

Set switches 1-6 to desired vend price by gently pushing the top of the selected switch with a pen. Make sure the vend price set on changer corresponds to the vend price indicated on the front of the vendor.

5. Ensure the flat "ribbon" wire from the acceptor is securely plugged into the back of the coin mech body.
6. Gently, tilt the acceptor panel upward with your fingertips until the spring clips lock it in place.
7. Plug changer power cord plug back into the door-mounted socket.
8. Fill change tubes with nickels, dimes & quarters.
9. Test with a variety of coins to ensure proper operation.

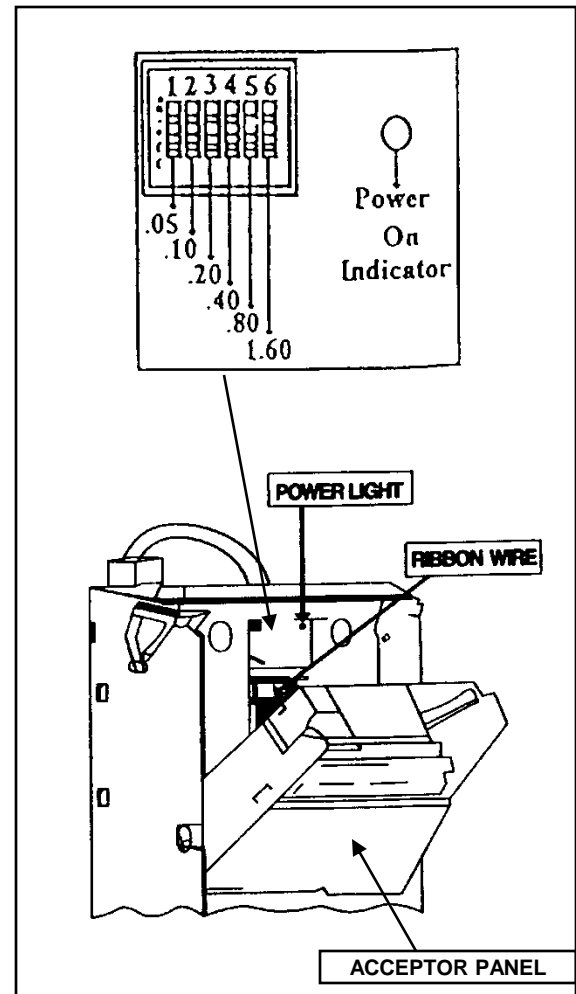

Diagram 1



The Leader in Premium Retailer Brand Beverage Innovation

Cott Vending Inc.

10838 Ambassador Drive

Creve Coeur, MO 63132

(800) 662-9225, option 1

The machine vends too many cans each time I press the button.

This is called “multiple vending.”

Please try these steps, and call us with your results.

Disconnect power by unplugging the machine or turning the breaker off.

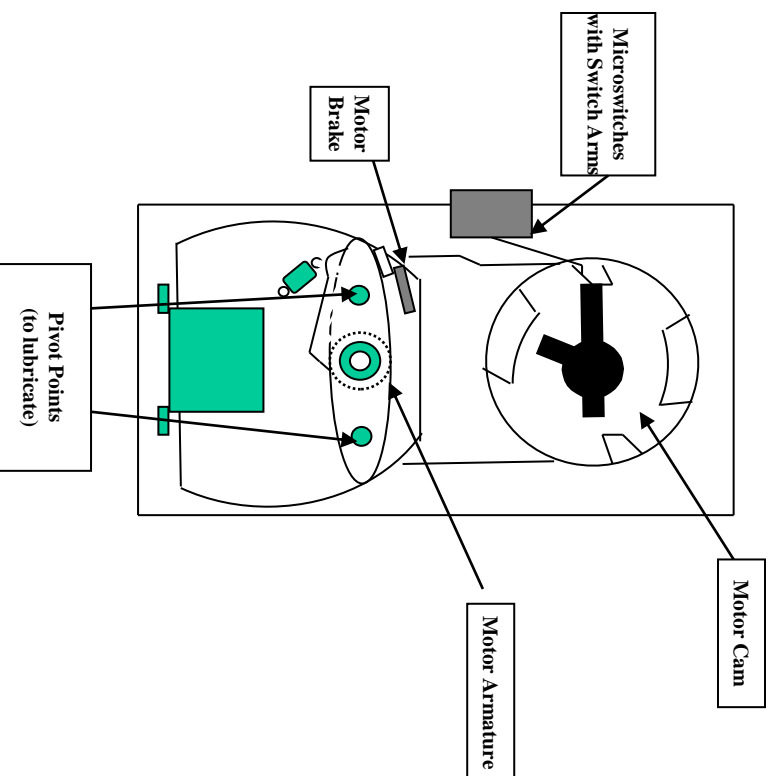

1. Open the front door of the vending machine.
2. After ensuring that there is no power to the vendor, remove the motor cover (a large sheet metal cover at the base of the columns, above the can chute, which may have a screw in center of its bottom that has to be loosened first).
3. Identify the column that is not vending correctly. Locate the motor at the base of that column. Check the motor brake. Is it spring loaded? Broken?
4. Locate the microswitches. Spray them heavily with Windex. **AVOID SPRAYING WINDEX ON PARTS OTHER THAN THE MICROSWITCHES.**
5. Allow the switches to dry completely (ten minutes or more), and plug the vendor back in.
6. Test vend by gently pushing the microswitch arms away from the cam, with a **plastic** ink pen. The machine should vend one can from the column.
7. If the problem has been corrected, **unplug the machine** and put the motor cover back on. Plug the machine in.
8. If the machine is still multi-vending, please call us at 1-800-662-9225, option 1.

The column(s) show sold out or will not vend. What can I do to correct this?
Follow the instructions below and call us at 800-662-9225, option 1 with the results.

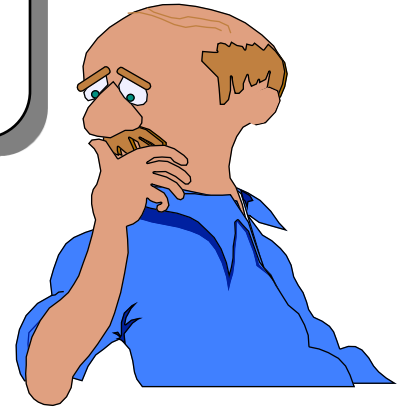

Narrow Motor

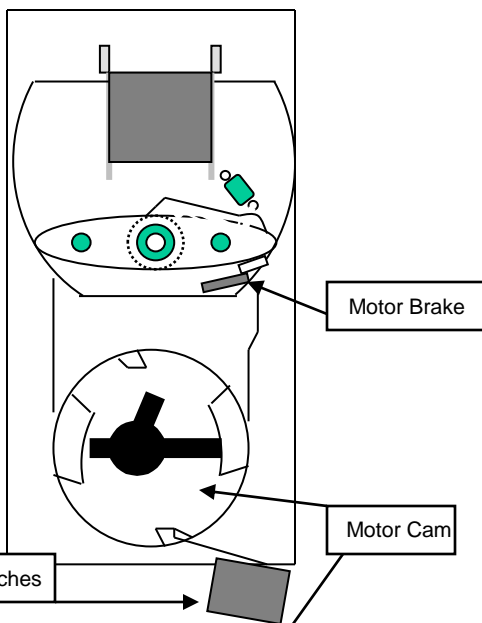

Wide Motor

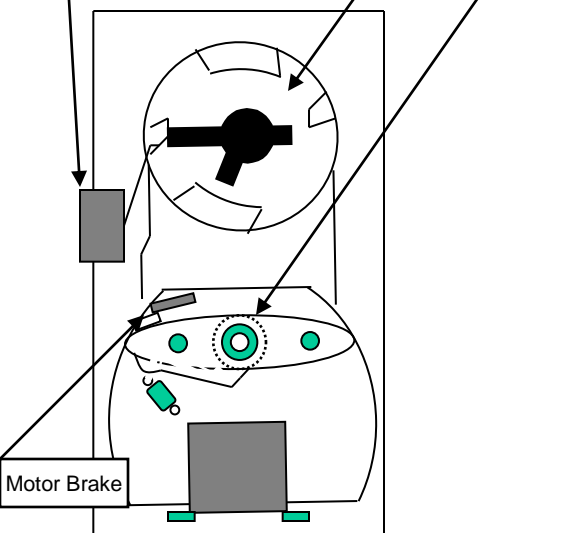

1. **Unplug the vendor for safety. Let the motors cool for 10-15 minutes.**
2. Open the front door of the machine.
3. Remove all cans in the column that shows a false sold out indication.
4. If you can not easily remove the jammed cans, remove the motor cover (large, rectangular sheet metal cover located above the can chute, which covers the motors at the base of each column). It is fastened with one phillips screw in the center of the bottom ledge. Loosen the screw and remove the cover by pulling it toward you.
5. Press and hold the motor brake release, and you will be able to rotate the motor arbor or cam to allow the jammed can to be removed.
6. With no product in the column, plug the machine in for a moment to allow the motor to reset.
7. **Remember, any time that you remove or reinstall the motor cover, unplug the vendor for safety.**
8. Reinstall the motor cover after unplugging the machine.
9. At this point, load the column with product. Plug the vendor in, and test the column with coins.

Refrigeration Check List.
Please check the following things and
call (800) 662-9225, option 1.
Thank you.



Is the vender cooling? _____

If not, is the evaporation coil covered with thick frost or ice? _____

This coil is found directly behind the can/bottle chute, inside and toward the back of the vender. The can/bottle chute is a sheet metal ramp that the can or bottle rolls down, to the delivery port, when vended.

If so, thaw the unit by unplugging the vender to let the ice completely melt. This may take several hours, up to an entire day.

NEVER use a sharp object to chip the ice away!

After thawing and **BEFORE PLUGGING THE VENDER IN**, check to see if there is standing water on the evaporation tray. _____

The evaporation tray(shelf) is directly under the can/bottle chute. If there is standing water on that tray, you will need to unclog the drain tube opening, located in the middle of the tray. This tube connects the evaporation tray to the condensation pan in the back of the vendor. To unclog the drain tube, use a thin object like a pencil or drinking straw to poke through the drain hole opening in the middle of that shelf pan. (Please be sure the straw or pencil is not left in the drain tube.) Be sure the water drains, and plug the vender back in.

The unit is equipped with a heater to keep the beverages from freezing when the outside temperature drops below 30 degrees. The heater is found to the left of the can/bottle chute, and is a metal unit with a mesh area covering the "U" shaped heating coil.

Is this "U" shaped coil glowing? _____ There is also a yellow light on that heater.

Is that yellow light on? _____

Take a piece of paper, and put it against both the evaporation coil (the one that may have been frosted, behind the triangular can/bottle chute) and the condensing coil (the one you see that looks somewhat like a car radiator, in the very bottom right side, when the door is open). Does the air flow suck the paper up toward the:

Evaporation coil _____?

Condensing coil _____?

Keeping the condenser coils (bottom of machine) brushed down to prevent accumulation of dust, and clearing the drain hole opening on the evaporation tray (under the sheet metal, triangular product chute) are the two most important things you can do to at the store, to prolong the life of the refrigeration system & reduce down time from refrigeration problems.



Temperature Control Setting Dixie-Narco 440

YOUR RETAIL BRAND VENDING MACHINE IS EITHER TOO WARM OR TOO COLD. THE FOLLOWING DIAGRAM AND INSTRUCTIONS WILL SHOW YOU WHERE TO LOCATE THE TEMPERATURE CONTROL UNIT IN YOUR MACHINE AND HOW TO ADJUST THE UNIT. IF YOU HAVE ANY PROBLEMS PLEASE CALL COTT BEVERAGES AT (800)662-9225, OPTION 1, AND WE WILL HELP TALK YOU THROUGH THE PROCEDURE.

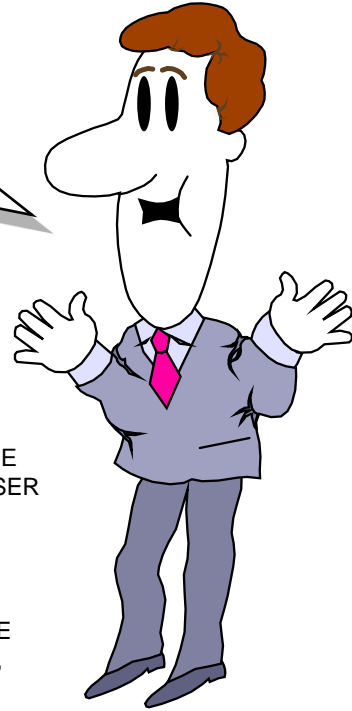

THE VENDOR TEMPERATURE IS REGULATED BY THE TEMPERATURE CONTROL, LOCATED NEAR THE RIGHT SIDE WALL OF THE CABINET. BEFORE ADJUSTING THE CONTROL, BE SURE THE REFRIGERATION SYSTEM IS WORKING PROPERLY. PLACE A PIECE OF PAPER AGAINST THE CONDENSER AND EVAPORATOR COILS TO ASSURE THE FANS RUN FREELY AND DO NOT MAKE EXCESSIVE NOISE. THE PAPER SHOULD "STICK" TO THE COILS, FROM THE FANS PULLING AIR (FRONT TO BACK, INSIDE). THE EVAPORATOR AND CONDENSER GRILLS SHOULD BE CLEAN AND FREE FROM DEBRIS. IN ADDITION, CHECK THE CONDITION OF THE INNER DOOR GASKET TO ENSURE A PROPER SEAL ON THE CABINET.

TO PROPERLY ADJUST, PLEASE SHUT THE COMPRESSOR OFF BY TURNING THE TEMP. CONTROL FULLY COUNTER-CLOCKWISE, THEN TURN BACK, CLOCKWISE, ONE THIRD OF A TURN.

TO LOWER THE CABINET TEMPERATURE, SLIGHTLY TURN THE TEMPERATURE CONTROL ADJUSTMENT CLOCKWISE.

TO RAISE THE CABINET TEMPERATURE, TURN THE ADJUSTMENT COUNTER-CLOCKWISE.

Off is Fully Counter-Clockwise.

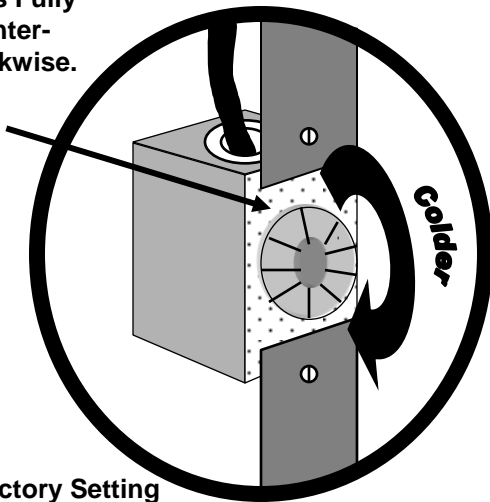

*Factory Setting is 1/3, Clockwise.

Can Chute

Temp. Control

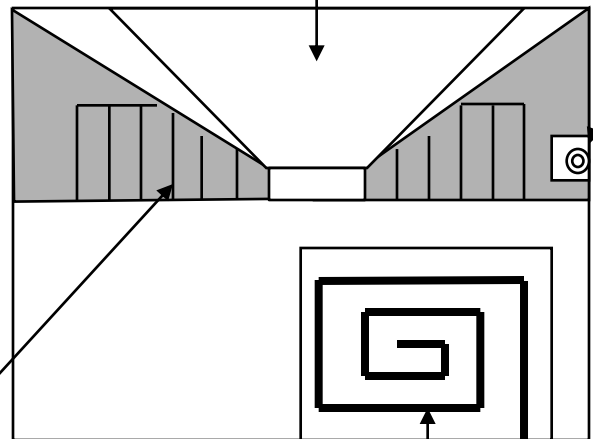

Cooling Coils (Evaporator)

Condenser Coils

Please call us at (800)662-9225, option 1 with your results. Thank you.

**The cooling coils are icing over.
What should I look for?**

1. Defrost the machine by unplugging it. (It may take up to 24 hours.)
2. Make sure the rubber door seal is not obstructed when closing the door.
3. Check for an outdoor heater (rectangular metal box under can chute with a horseshoe shaped heating element). The heater should only be on when the machine is outdoors and the temp. is below 32 degrees. The orange light on the heater should NOT be lit.
4. Make sure there is no standing water in the machine. There is a drain just left of center towards the front of the machine under the can chute. If it becomes clogged the water will accumulate in the cabinet. The excess moisture will cause the coils to freeze.
5. Check for air flow in the cabinet. There is a fan directly behind the cooling coils. If the fan is not working the coils will freeze. The fan pulls air through the coils, which will create suction at the front of the coils. See if a piece of paper is pulled to the coils. This will help verify sufficient air flow.
6. Please call Cott with the answers to these questions. (800)662-9225, option 1. Thank you.



OUTDOOR
HEATER

